

REVISIONS

ZONE	LTR	DESCRIPTION	DATE	REVISED	APPROVED
	△				

DB

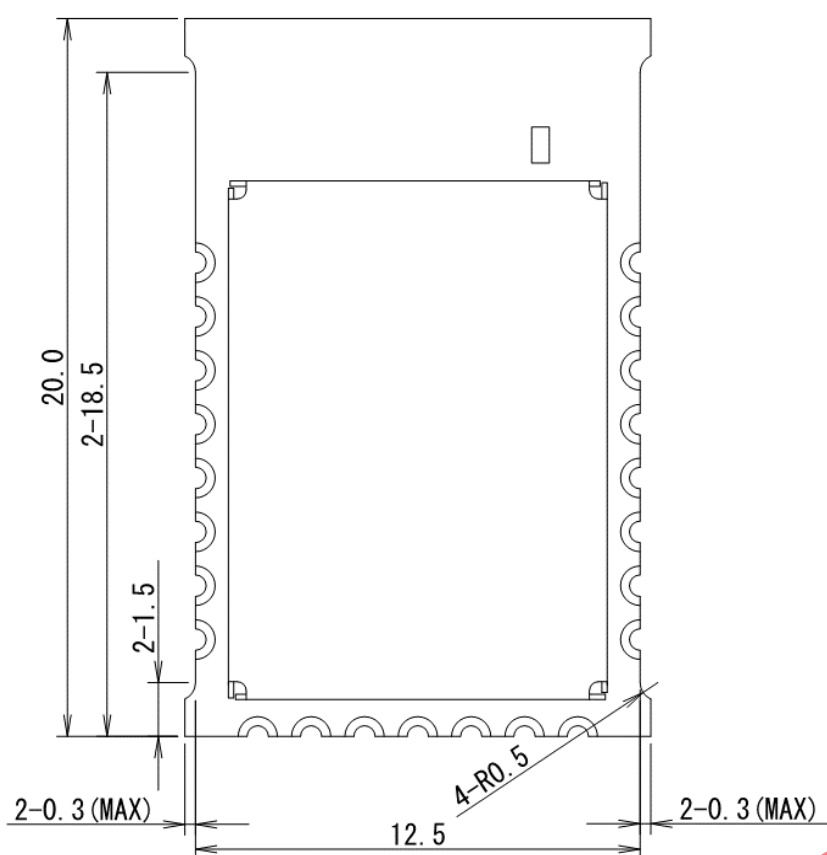

<Top View / Top 面視>

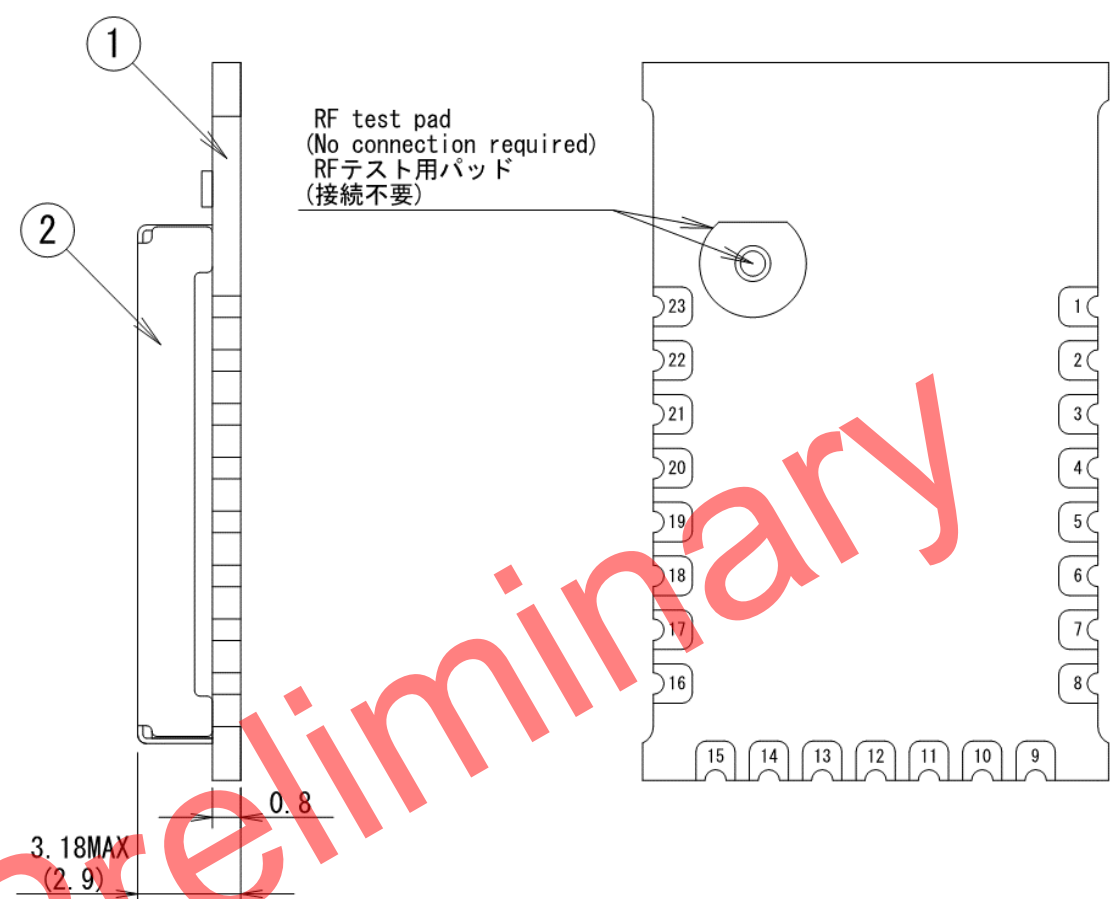

RF test pad
(No connection required)
RFテスト用パッド
(接続不要)

* RF test pad is Internal Use Only.
<Bottom View / Bottom 面視>

Pin assignments / ピン配置

No.	Name
1	GND
2	GND
3	DIO_30
4	DIO_29
5	DIO_28
6	DIO_2
7	DIO_3
8	VDDS
9	DIO_19
10	DIO_20
11	JTAG_TMSC
12	JTAG_TCKC
13	DIO_16
14	DIO_17
15	DIO_21
16	DIO_23
17	DIO_24
18	DIO_25
19	RESET N
20	GND
21	DIO_26
22	GND
23	GND

Note / 注記

- Tolerances are +/-0.2mm, unless otherwise specified.
指定なき寸法公差は、±0.2mmとする。

UNLESS OTHERWISE SPECIFIED DIMENSIONS ARE IN MILLIMETERS INCHES TOLERANCE ON
DECIMALS± FRACTIONALS± ANGLES± DO NOT SCALE DRAWING

2	Shield Case	1			
1	PCB	1			
LTR	Part Name	QTY	Material		
Drawn by		Date		Model Name	
Checked by		Date		Bluetooth LE Module	
Approved by		Date		Product Number	
Hosiden Corporation Issue:			Scale	HRM3012-010010	
<input checked="" type="checkbox"/> OSAKA <input type="checkbox"/> TOKYO <input type="checkbox"/> F·D <input type="checkbox"/> KYUSHU <input type="checkbox"/> SEIKO <input type="checkbox"/> HEM			NTS	Drawing Number	
				HRM3012-010010DB	

REVISIONS				
ZONE	LTR	DESCRIPTION	DATE	APPROVED

DB

Marking contents / マーキング内容

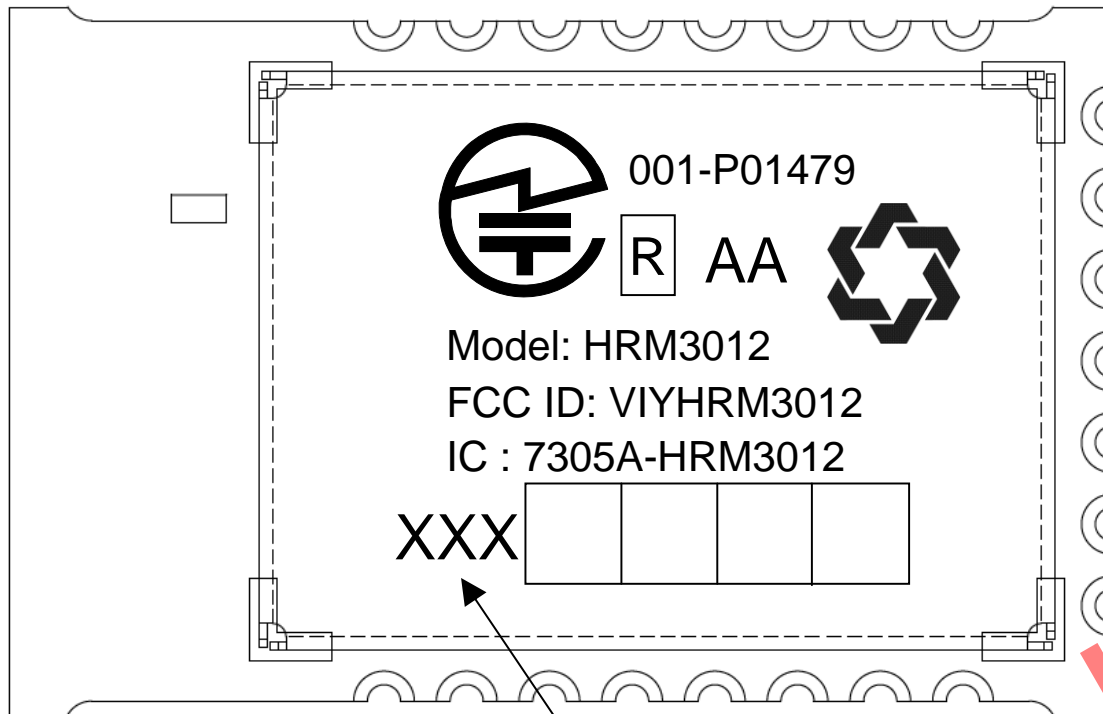

Manufacturing lot code
製造密番

This area may be marked for production control.
この範囲には生産管理用のマーキングがされる可能性があります。

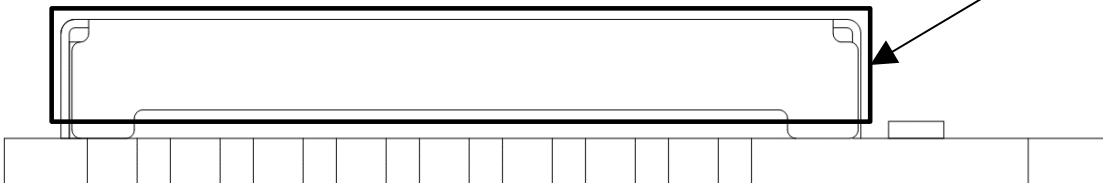

Preliminary

UNLESS OTHERWISE SPECIFIED DIMENSIONS ARE IN MILLIMETERS INCHES TOLERANCE ON
DECIMALS± FRACTIONALS± ANGLES± DO NOT SCALE DRAWING

LTR	Part Name	QTY	Material	
				Model Name
				Bluetooth LE Module
				Product Number
				HRM3012-010010
				Drawing Number
				HRM3012-010010DB
			Scale	NTS

Hosiden Corporation Issue:
 OSAKA TOKYO F·D
 KYUSHU SEIKO HEM

HRM3012ブロック図

